

Proton and Neutron Irradiation Facilities

(E.W. Blackmore, TRIUMF)

This was another busy year for the proton and neutron irradiation facilities with 63 users from 20 different companies or institutions making use of the accelerated beam testing facilities at TRIUMF.

Proton irradiation facility

During the year there were seven scheduled periods for proton testing on the low energy beam line BL2C and during the two periods in September and December the high energy beam line BL1B was also available.

There has been an increased use of the BL2C protons to produce a low flux neutron beam (10^3 to 10^4 neutrons $\text{cm}^{-2} \text{s}^{-1}$) for the irradiation of large systems that require a uniform beam over dimensions of about $50 \text{ cm} \times 50 \text{ cm}$. The neutrons are produced by stopping 116 MeV protons in a lead beam stop and then placing the test equipment 1.4–3.5 m downstream of the beam stop. The high energy neutron flux is calibrated using activation of carbon foils and the real time measurement is made using a moderated BF3 counter positioned behind the test equipment. FLUKA calculations are used to determine the neutron energy spectrum and to compare the absolute flux against the measured results. There is good agreement with the >10 MeV neutron flux as measured from carbon activation and calculated using FLUKA. Teams from Cisco Systems made use of this neutron beam on four occasions this year for testing of their router systems and several other groups used it as well for neutron SEU work.

The Sandia/CEA/TRIUMF collaboration continued its work on Expt. 1062/986, proton radiation effects in advanced semiconductor technologies. As in previous years this experiment had a number of different studies and these are described in detail in the Science section of this Annual Report.

The Canadian groups primarily used protons for space radiation effect testing and these groups included MDA, UTIAS, ABB-Bomem and Teraxion.

Neutron irradiation facility

The high flux neutron beam at the final beam dump on BL1A has an energy spectrum that is similar to the atmospheric spectrum from below 1 MeV to the highest neutron energies around 400 MeV. The neutron rate above 10 MeV is about 2×10^6 neutrons $\text{cm}^{-2} \text{s}^{-1}$ at BL1A currents of $100 \mu\text{A}$. A substantial flux of thermal neutrons is also present. This beam is present whenever BL1A is operating, so it can be used parasitically for more than 4000 hours per year. However, neutron users presently take about 200–300 hours per year.

The users come from the aircraft industry or from groups wanting to test individual components for terrestrial neutron effects where the high intensity allows for rapid testing of devices from different manufacturers. Most of the users for this facility came from outside of Canada.

Proton Therapy Facility

(E.W. Blackmore, TRIUMF)

In 2006 there were 12 patients treated with protons during five scheduled treatment sessions. This brings the total number of patients treated at TRIUMF to 116. Of the 12 patients treated, 9 were for choroidal melanoma, 2 for iris tumours, and 1 for a ciliary body melanoma. Figure 1 shows the patients per year since the start of treatments in 1995.

The treatment system continues to be stable and quite reliable although there is concern for the longer term in the controls of the patient chair as the components are no longer manufactured. There were no significant changes made to the treatment system hardware or software this past year.

A group from DKFZ in Heidelberg carried out a series of measurements of protons of different energies scattering in a water box containing bone phantoms placed at differing depths. This work was to compare simulation programs used in treatment planning with actual measured data of energy and transverse scattering distributions.

TRIUMF Proton Therapy Patients

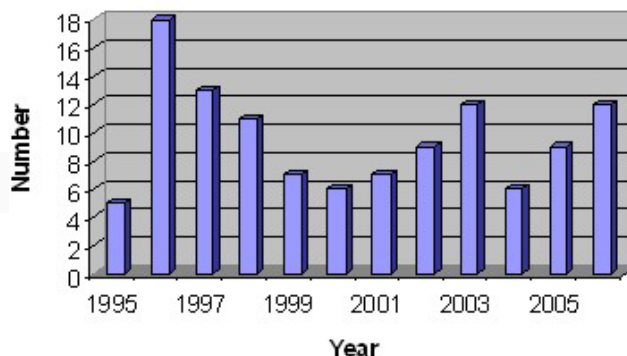

Fig. 1. Number of patients treated with protons per year.

ATLAS Tier-1 Centre

(R. Tafirout, TRIUMF)

TRIUMF is hosting Canada's Tier-1 computing centre for the ATLAS experiment at CERN's Large Hadron Collider (LHC) and is part of the world's most advanced network and computing grid. Funds for the centre in the amount of \$10.5M (\$8.0M in capital, \$2.5M in operating) have been secured by a consortium of Canadian universities from the Canada Foundation for Innovation through its Exceptional Opportunities

Fund program, while an additional \$4.0M grant request from the BC Knowledge Development Fund (BCKDF) has also been secured. The proposal was led by Simon Fraser University (M. Vetterli, SFU/TRIUMF).

The ATLAS experiment will collect 3–4 PB (1 PB, or petabyte = 1 million gigabytes) of data for each year of its operation, when fully commissioned. Secondary data sets resulting from event reconstruction, reprocessing and calibration will result in an additional 2.5 PB for each year of data taking. This requires massive computing resources in both CPU and storage (disk and tape media) that cannot be aggregated into a single centre. Therefore, the data will be distributed and accessed internationally within the Worldwide LHC Computing Grid (WLCG). By the year 2010, the computing resources at TRIUMF will consist of about 4000 kSI2K (1 kSI2K corresponds to a year 2000 equivalent 3 GHz CPU), 3 PB of disk storage, and 2 PB of tape storage.

The ATLAS computing model is based on a Tier structure, where CERN (Tier-0) will collect and store the primary raw data that pass the high level trigger (HLT). The Tier-0 will also produce a first pass reprocessing dataset. Primary and reprocessed data will be distributed to the Tier-1 centres around the world. Each Tier-1 will only be a custodian of its share of this data, and is expected to provide collaboration-wide access around the clock. The Tier-1 centres will perform further reprocessing of the primary data when better calibration constants of the ATLAS detector are made available, therefore producing better quality data for physics analyses. Eleven Tier-1 centres are currently being developed and deployed worldwide to serve all four LHC experiments. These Tier-1 centres are primarily located at national laboratories of some of the participating countries to the project. Each Tier-1 centre will be coupled with a set of Tier-2 centres. Tier-2 centres will be based at the universities primarily and will be producing the simulated datasets needed for the experiment. The simulated data will be uploaded to the Tier-1. ATLAS wide user analysis will be done at the Tier-2 centres, which is their second biggest role in the ATLAS computing model.

The challenge is therefore to build, maintain and operate a large scale data intensive analysis facility for 24×7 operations. All services have to be provided with high reliability and availability according to the WLCG Memorandum of Understanding (MoU) which was signed by TRIUMF in October of 2006.

Grid services and hardware resources

Various services are being provided:

- Grid baseline services:
 - CE: Compute Element (to provide access to

- computing/CPU resources)
- SRM: Storage Resource Manager (disk/tape storage)
- FTS: File Transfer Service (data movement between sites)
- LFC: LCG File Catalog (file location and metadata)
- VOBOX: ATLAS Data Management (datasets handling)
- Databases: Oracle (ATLAS conditions data and events metadata), MySQL, PostgreSQL
- WEB services (monitoring)

In 2006 we effectively moved away from a Tier-1 prototype to a fully functional system providing production quality service for ATLAS on a continuous basis. In the early fall of 2006, the CPU capacity was significantly increased with the purchase of 96 processor cores (latest Intel Woodcrest processors running at 3 GHz). With respect to storage capacity: 12 TB of disk and 12 TB of online tape capacity were available.

We also acquired an Oracle Real Application Cluster (RAC) solution as part of LCG Distributed Database Deployment (3D) project. The current RAC configuration consists of two server nodes accessing 6 TB of raw storage using fibre channel connectivity (SAN configuration). The RAC configuration is shown in Fig. 1. In 2007, ATLAS will be conducting a Database service challenge so we have to ensure readiness for these tests to be successful.

During the summer of 2006, we went through a Request For Information (RFI) process with many vendors in order to be familiar with the latest technology trends and future changes with respect to CPU architecture and disk storage, and to also determine the extent of the infrastructure that is required with respect to power and cooling.

Networking

Since the spring of 2005, two dedicated 1 Gb/s lightpath links between TRIUMF and CERN were made available and used for the service challenges as well as for regular production service. The links were provided by CANARIE. In November of 2006 a 5 Gb/s link was commissioned, which is a follow up of a Memorandum of Understanding between HEPNET, CANARIE and TRIUMF to establish the proper Tier-1 connectivity as part of the LHC Optical Private Network (OPN). For the connectivity to the planned Tier-2 centres in Canada, two dedicated 1 Gb/s lightpaths were established: one between TRIUMF and the University of Victoria, and one link between TRIUMF and The University of Toronto. The connectivity to Simon Fraser University and to the University of Alberta uses the dedicated 1 Gb/s Westgrid link at present. Further

dedicated links will be established in the near future to ensure sufficient connectivity between TRIUMF and the Tier-2 centres during steady LHC operations.

Service challenges

To test the LHC experiments computing models, several Service Challenges phases have been planned. The Service Challenges are meant to test the robustness of Grid middleware services, storage access and networking at several sites in order to ensure readiness for LHC start-up in 2007. In early 2006 a re-run of Service Challenge phase 3 was conducted. It consisted of file transfers between CERN and several Tier-1 sites achieving an aggregate rate of 1 GByte/s throughput which was a major success (as seen in Fig. 2). A press release was issued by TRIUMF. In the spring of 2006 Service Challenge phase 4 was conducted for several weeks involving disk → disk and disk → tape file transfers. TRIUMF performed very well in those tests as can be seen in Fig. 3.

Infrastructure design

The computing centre will be housed in the ISAC-II building and will require important infrastructure work in order to bring power, cooling and networking to the centre. The available floor space is only about 900 sq. ft. The design of the cluster should be optimized and take into account the space limitations. With respect to power consumption, the current estimates are 175 kW for the computing nodes (CPU), 75 kW for the disk storage and 25 kW for the remaining components (tape library and drives, network switches, Grid services and database nodes). The air conditioning/cooling system will use about 100 kW. Its design will be critical for the centre and various options have been explored and a solution based on liquid cooling is favoured due to the very high heat density (up to 400 Watts/sq. ft.). The current design layout is shown in Fig. 4.

Personnel

All the personnel (5) dealing with system administration and operations of the Tier-1 centre were effectively hired in 2006: a senior/lead system administrator (Denice Deatrich), a Grid computing expert (Rodney Walker), a storage expert (Simon Liu), a database expert (Jim Li), and a networking expert (Chris Payne). The current operation model is that while having a specific area of expertise, all personnel will also be knowledgeable about other operational aspects of the Tier-1 centre as a whole in case someone is on leave and backup is required. Some of the Tier-1 personnel perform frequent travel to CERN in particular to participate in various meetings and workshops where TRIUMF presence and representation is

required and preferable. Rodney Walker is ATLAS production system coordinator for the generation of simulated datasets on the Grid.

On the managerial aspect: R. Tafirout is Canadian representative on the LCG Grid Deployment Board (GDB), the LCG Management Board (MB), and the International High Energy Physics Computing Coordination Committee (IHEPCCC). M. Vetterli (SFU/TRIUMF) is Canadian representative on the ATLAS International Computing Board (ICB), the WLCG Overview Board (OB), the LHC Computing Resources Review Board (C-RRB) and the WLCG Collaboration Board (CB).

Availability and reliability

Various site functionality tests are conducted on a regular basis by WLCG, so site availability and reliability is being continuously monitored and reported. It is important to see whether a site satisfies the MoU requirements. TRIUMF is one of the most reliable sites among all the Tier-1's, and was above 90% of MoU target value for several months. Figure 5 shows the availability and reliability of TRIUMF as measured by WLCG from May–December of 2006. We have been very proactive in fixing problems, either related to Grid services or storage, in a timely fashion. We are continuously improving our monitoring and are about to implement 24×7 operational procedures in order to satisfy the MoU target requirements.

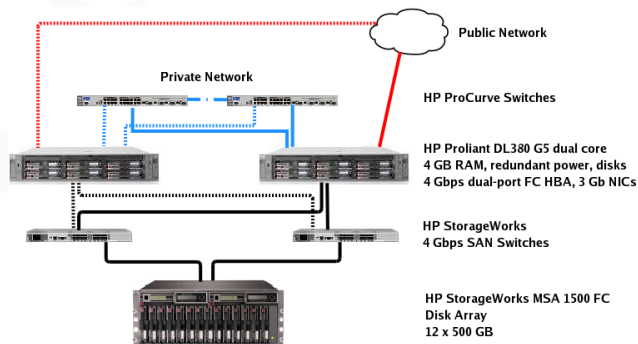

Fig. 1. Oracle Real Application Cluster.

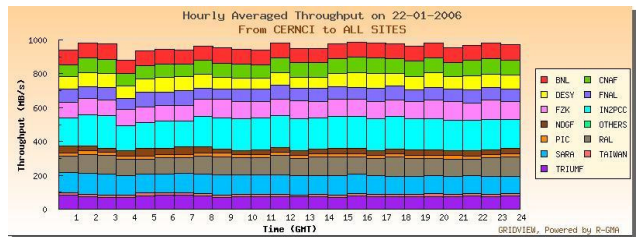

Fig. 2. Service Challenge 3 re-run in early 2006.

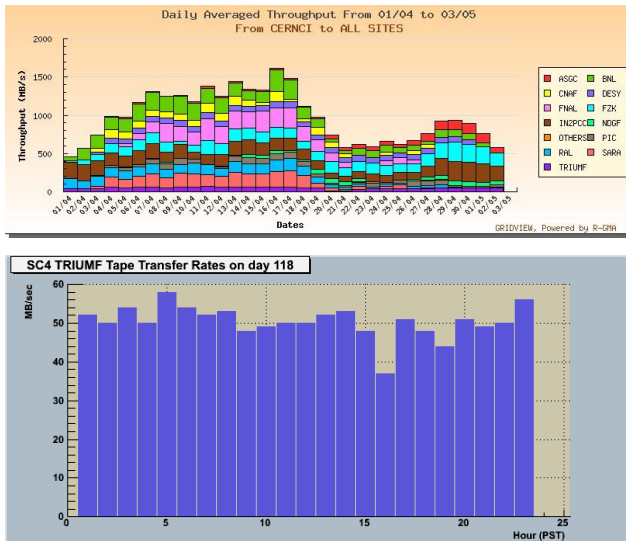

Fig. 3. Service Challenge 4 at nominal rates for disk → disk (top) and disk → tape (bottom) transfers.

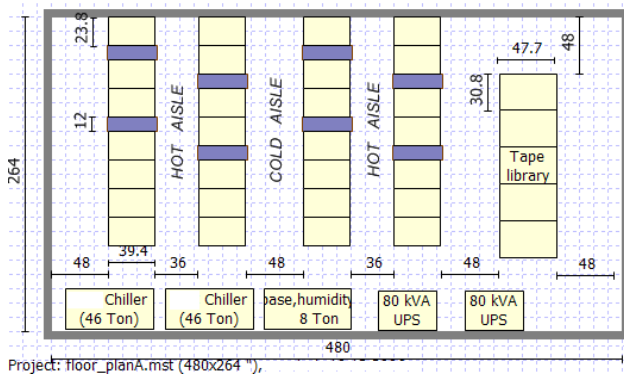

Fig. 4. Design layout of the data centre.

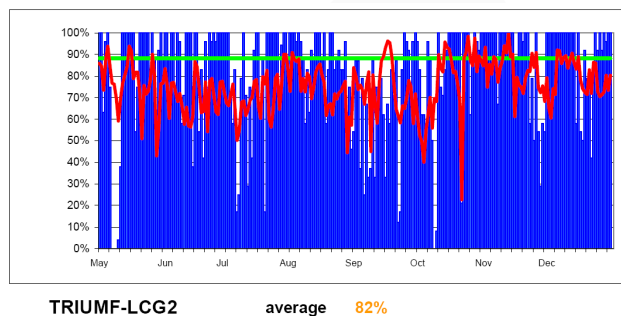

Fig. 5. TRIUMF's availability and reliability for May–Dec 2006. MoU target shown in green.

Data Acquisition Systems

(P-A. Amaudruz, TRIUMF)

Overview

The year 2006 has been a busy year for the DAQ group as new experiment set-ups have emerged and required attention (TITAN, PIENU, T2K-TPC, T2K-FGD, ALPHA, LiXe). In parallel, multiple smaller detector development DAQ test benches were necessary for R&D on those same larger experiments.

As the number of experiments increase, the need for greater computing power has in the last 2 years doubled the DAQ computer park with more than 60 computers dedicated to data acquisition. The management of such a park is not trivial; therefore effort has gone into restructuring the DAQ web site providing a more compact location for all DAQ-related information. This work has done in part by summer students and resulted in a successful Web site, including an inventory system accessible through <http://daq-plone.triumf.ca/>.

Software support has been addressed by providing new hardware device drivers within the standard DAQ package (MIDAS) and inviting Dr. Stefan Ritt from PSI to TRIUMF during the summer 2006, to focus on the multi-threading aspect of the slow control frontend, as well as multiple details such as 64 bit support, etc.

While software support is the main task of the DAQ group, the trend is moving towards a closer device programming scheme to provide better optimized capabilities and performances from the hardware. Physical devices such as Field Programmable Gate-Array (FPGA) or Application Specific Integrated Circuit (ASIC) are now common, and require special knowledge which we gained by collaboration with the electronic groups in developing specific TRIUMF hardware modules such as the VF48, VT48, VPC6, etc.

Data acquisition operations

Over the last 2 years, the DAQ group supervised two coop students i.e. Ms. Qing Gu, working on the migration of the DAQ web pages to the PLONE content management system, and on supporting the ISAC-II beam diagnostics DAQ system; and Mr. Simon Claret, developing a Web-based inventory system for DAQ and LADD equipments. The main topics regarding software development have been MIDAS drivers for the CCUSB USB-CAMAC interface, support for the SY2527 High Voltage system, development of the ROODY online data display program, ROOT-based online and offline data analysis packages (currently being used by Dragon, ALPHA and PIENU), Linux devices drivers for PMC waveform digitizer (TITAN), VME drivers for the SIS3820, VF48, VT48 and other modules, bug fixes and improvements to the MIDAS DAQ package.

The DAQ group maintains a large number of general computers and dedicated DAQ stations. During 2006, continuing maintenance of these machines saw phasing out of obsolete hardware, CPU and memory while providing disk upgrades to the DAQ stations. Standardization of operating systems to Scientific Linux 4 as well as improved monitoring of computer performance and health using ganglia and triumph_nodeinfo scripts. The group also contributes

to general TRIUMF computing by providing expert knowledge. Konstantin Olchanski built and maintains the mirror.triumf.ca node used as the local source for nightly operating system updates, he's maintaining system update scripts and the site backup system using AMANDA. Further upgrades to increase the backup capacity in the upcoming year are planned.

DAQ systems

TWIST, PIENU and μ SR have been the main experiments in the Meson Hall while in the ISAC-I, the HEBT beam line DAQ was upgraded with a new computer for running the E992 experiment in the Summer of 2006. The LTNO experimental station has been decommissioned as well as the DAQ system from which some hardware has been recycled for the upcoming TITAN experiment. While some of the current experiments have been stable for several years, and require minimal attention from the DAQ group, more recent experiments such as PIENU, Liquid Xenon, μ SR, TITAN have required extra effort from the DAQ group. Parallel to these set-ups, standalone DAQ for test bench of detectors (T2K, TACTIC, HEBT, ...) have also required time for set-up.

μ SR, β -NMR and β -NQR at ISAC

The operating system of all 9 μ SR DAQ machines were updated to SL4.3. Similar upgrades for β -NMR and β -NQR have been done.

"Dual channel" operation, where the beam is alternated between the β -NMR and β -NQR channels, has been used very successfully during the β -NMR group's beam periods this year. This modification has been of great benefit, since while one channel is taking measurements after the beam is switched off, the other channel is using the beam to take data. Thus very little of the beam is wasted, and more experiments can be run during the beam period. Running as a "single channel" where only one of β -NMR or β -NQR is active is, of course, still an option. The modifications to the DAQ together with the hardware changes to the PPG and to the EPICS Helicity switch were designed to ensure that switching the DAQ between "dual channel" and "single channel" is as easy as possible for the users.

Data were also taken during the beam period using a new experimental mode, "LCR", a combination of the existing "SLR" mode, and the "CAMP" scan mode, whereby a magnet (controlled by CAMP software) is scanned.

DRAGON

The Dragon group was assisted with testing of their latest VME ADCs and will move to a Linux/VMIC based VME system in a near future.

TWIST

More powerful host computers were installed in the TWIST DAQ set-ups and contributed to very smooth data taking in 2006. TWIST acquired some 22 TB of data, mostly in the fall beam period.

Stability improvements have been made to the slow controls system, a software interlock was implemented between the gas system and the high voltage system, the local data acquisition network was upgraded to Gigabit Ethernet and the muon stopping position regulator was fine tuned.

TITAN

Initial work was started on the DAQ for TITAN. The control of the operation sequence for the different measurement cycles for the MPET station will be managed by a VME sequencer board (PPG). The PPG (TRIUMF Pulse Programmer VME module incorporating a Pulseblaster) has been successfully used on β -NMR/ β -NQR experiment; however for TITAN the experimental parameters to program and control the PPG will be input using predefined blocks in the MIDAS ODB, rather than fixed templates as was used for β -NMR/ β -NQR. Similar blocks will also be used to input the parameters for controlling the RF and programming the Arbitrary Waveform Generator (AWG). The main DAQ processor is a VME VMIC-7850 allowing for 3 PMC interface such as one Arbitrary Waveform Generator (AWG), one CANBus interface and possibly multiple RS232 interface. It was decided to use VME & CANBus to control dedicated experimental devices such as the High Voltage and Temperature. A MIDAS slow control driver has been written for that purpose using the TPMC810 PMC interface. Parallel to this option, EPICS will have initial control of those CANBus units until full understanding of the operation requirements with the complementary traps (EBIT) is available.

8π , TIGRESS

Gigabit network was constructed to link the ISAC-I counting room, 8π area, HEBT area and TIGRESS lab in order to cope with the high data rate. 8π DAQ station has been upgraded with a new main computer, new VME CPU, and gigabit network link. For TIGRESS, a new DAQ system was built for running their first experiment in ISAC-I. While the 8π DAQ is in its stable phase, the TIGRESS DAQ is evolving as the hardware is brought into the experiment. Dedicated VXI (TIG10) and VME modules (TIGCOL) developed by Jean-Pierre Martin from U. of Montreal have been implemented. The DAQ group has been involved in the overall data acquisition and more specifically into driver software development.

PIENU

The PIENU experiment was installed in M9A in the fall of 2006 and started using the former RMC counting room. A full VME DAQ system was deployed including a standard 6U VME crate containing CAEN ADCs and TDCs, TRIUMF VMEIO, VF48 plus a custom trigger module and a KEK Copper system, which is a modified 9U VME crate, containing two KEK 500 MHz digitizer modules with 4 channels each. The two crates were operated in parallel using hardware event number synchronization and a MIDAS software event builder. 1.5 TB of data were accumulated in less than two weeks. The main contributor to dead time was the VF48 used with minimal processing in the firmware. Several improvements to the VF48 firmware are underway to provide zero suppression, internal event buffering and faster readout throughput.

T2K

The T2K experiment is composed of different sub-detectors for which TRIUMF is responsible i.e. the TPC (Time Projection Chamber) and the FGD (Fine Grained Detector). In the Detector Facility, parallel activities centred on both projects took place. For the T2K prototype TPC tests, ALICE TPC electronics were brought from CERN and a DAQ system has been developed and deployed at UVic. Installation and final debugging required several trips by Konstantin Olchanski to UVic. This system is unique in using dual USB interfaces to acquire TPC data. The TPC gas system required another DAQ set-up using the Canary Chamber for long term gas characteristics measurements. The FGD based on the SiPM photo-sensor has also a dedicated DAQ station for light yield and characterization of the SiPM in the detector facility as well as SiPM Photo-sensor performance monitored in the M11 area with beam particles.

In parallel, a portable scanning DAQ system and a permanent light yield measurement DAQ system were developed to process the 12,000 scintillator bars produced last fall. Both of these systems made use of a bar code scanner to record each bar serial number before taking measurements. The portable system consisted of a laptop, bar code scanner connected via USB, two calipers to measure the rectangular section of each bar and a camera to take pictures of the ends of the bars. The system operated under MIDAS software. Semi-online analysis of the results allowed feedback to the operators when any deviation started to appear. The light yield measurement system consists of a Keithley Picoammeter to measure current from a photodiode, a set of motors to control the position of a source on a 4×2 metre XY table and a bar code scanner. This is used to measure light yield from scintillator bars with

automated movement of a source along the length of the bar in a couple of minutes.

Liquid Xenon

In early 2006, the first run of the Liquid Xenon set-up took place over a 3 month period. The overall data recorded during that period reached over 5 TB. The acquisition involved waveform digitizer at 1 Gbps and 20 Msps as well as multiple ADCs and TDCs modules. The online monitoring and analysis was based on the ROME framework analyzer and ROOT.

ALPHA

Throughout 2005 and 2006, Konstantin Olchanski worked on the design and development of the MIDAS DAQ system for the ALPHA anti-hydrogen production and trapping experiment at CERN. In the summer of 2006, the DAQ system was installed at CERN and successfully used during the first data taking run of the experiment.

Other development

Following the R&D for the Kopio experiment which was cancelled mid-August 2006, the development of the main acquisition boards such as the waveform digitizer and TDC has been repackaged to fit a standard VME board. While the VF48 (48 channels Waveform digitizer 20–65 Msps) has been developed and manufactured by Dr. J.-P. Martin/U. of Montreal in collaboration with TRIUMF, the VT48 (48 channels TDC deatimeless, 625 ps) and VPC6 VME modules have been developed by Chris Ohlmann from the Micro Structure Lab. The VPC6 complements the VF48/VT48 as a generic Power & Control module for 6 possible frontend cards (pre-Amps). Currently available frontend cards are the 16 ch. cathode pre-amp based on the Buckeye and the 16 ch. anode pre-amp based on the ASD01. This VPC6 module contains a power distribution bus and 6 serial links for which a dedicated FPGA provides the VME interface for frontend configuration.

Other VME card such as the V1190 (CAEN 64 ch TDC 200 ps), V792/V785 (CAEN 32 ch QDC/Peak Sensing), V1729 (4 ch waveform digitizer 1,2 Gbps) are now available for testing with the corresponding MIDAS drivers.

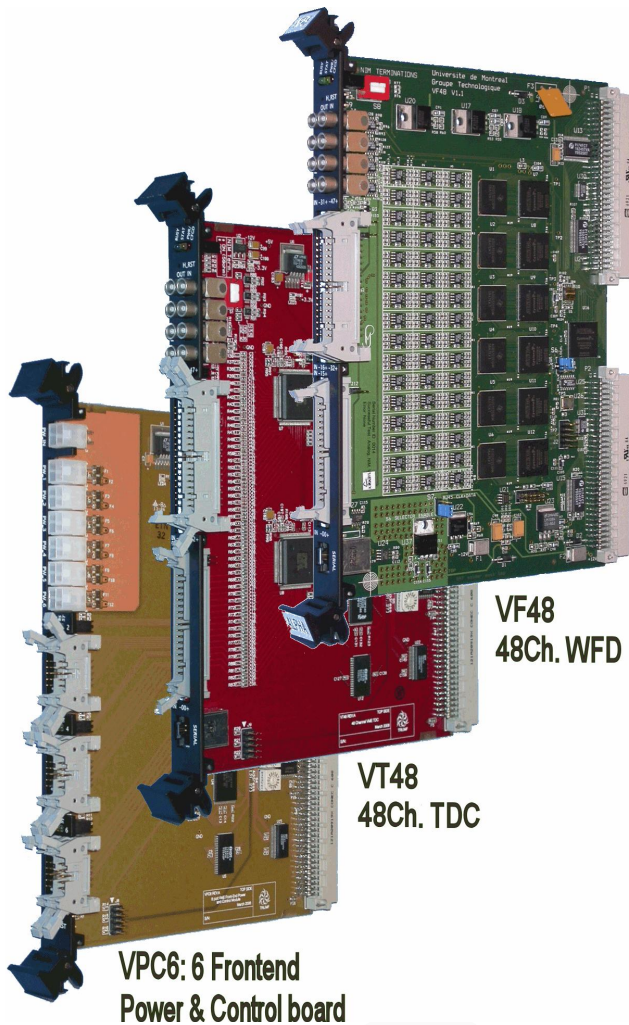

Fig. 1. VPC6, VT48, VF48 VME DAQ boards.

GEANT4

(P. Gumplinger, TRIUMF)

Modern particle and nuclear physics experiments require large-scale, accurate and comprehensive simulations of the particle detectors used in these experiments. The same is true for other disciplines such as space science, nuclear medicine, accelerator design and radiation physics. The demand is driven by the escalating size, complexity, and sensitivity of the detectors and by the availability of moderate-cost, high-capacity computer systems on which larger and more complex simulations become possible.

In response to this demand, an object-oriented toolkit, Geant4, has been developed for the simulation of particles passing through matter. It provides a comprehensive, diverse, yet cohesive set of software components which can be employed in a variety of settings, from small stand alone applications to large scale detector simulations for experiments at the LHC and other facilities. At the heart of this software system is

an abundant set of physics models, including electromagnetic, hadronic and optical processes, over a wide energy range starting, in some cases, from 250 eV and extending in others to the TeV energy range.

GEANT4 was designed and is being developed by an international collaboration, formed by individuals from a number of cooperating institutes, HEP experiments, and universities. It builds on the accumulated experience in Monte Carlo simulations of many physicists and software engineers around the world. The development of the Geant4 toolkit continues in response to the evolving requirements of a user community which is not only growing but has also become more diverse. In particular, the work on Geant4's physics capabilities represents a continuous effort to improve the simulation accuracy, while a significant effort is also invested in the validation of its physics models.

Making an optimal selection of a set of physics models among those available in the Geant4 toolkit, can present a daunting learning curve for the user, especially for hadronic interactions. For the same combination of projectile and target at a given energy, there can be several models applicable with different accuracy, strengths and computational cost. By using a consistent, tailored set of models it is possible to address the requirements of a particular use case. Choosing among the Geant4 hadronic models is made easier by a number of *Physics Lists*. Each *Physics List* is a complete and consistent collection of models chosen by experts to be appropriate for a given use case.

GEANT4 is also an ideal framework for modeling the optics of scintillation and Čerenkov detectors and their associated light guides. This is founded in the toolkit's unique capability of commencing the simulation with the propagation of a charged particle and completing it with the detection of the ensuing optical photons on photo sensitive areas, all within the same event loop. This functionality of GEANT4 is now employed world-wide in experimental simulations as diverse as ALICE, ANTARES, AMANDA, Borexino, Icarus, LHCb, HARP, the Pierre Auger Observatory, and the GATE (Imaging in Nuclear Medicine) Collaboration. The optical photon physics functionality in Geant4 was initially developed entirely at TRIUMF. The development now continues in collaboration with LIP (Portugal), Iowa State University and General Electric Research.

We are constantly responding to inquiries posted on the G4 Users Forum. Questions and feedback about Optical Photon Physics arrive from people working in medical PET research, cosmic shower research, neutrino detectors, HEP experiments and also from corporate research laboratories. During the last year

alone, email queries arrived in chronological order from the University of Virginia, University of Science and Technology of China, University of Illinois at Urbana-Champaign, Universidad de Granada/Spain, Universidad de los Andes/Columbia, INFN-Bari/Italy, Hellenic Open University/Greece, LIP/Portugal, High Energy Astrophysics at IKI/Moscow, ISRO Satellite Centre/India, SLAC, LANL, CALTECH, Sung Kyun Kwan University/Korea, JLAB, University of Sheffield/UK, SAMSUNG/Korea, INFN-Pisa and INFN-Roma/Italy, IN2P3-Grenoble/France, Florida International University, University of Texas at Austin, Iowa State University, Uludaq Universitesi/Turkey, LLNL, Imperial College/UK, Sandia National Laboratories, Universität Kiel and Uni Bonn/Germany.

Geant4 version 8.0 was released in December 2005. It included a thorough review of the important multiple scattering process - how the scattering angle is sampled, the calculation of lateral displacement, the conversion between physical step length and geometrical (linear) step length and how the process limits the simulation step. The new implementation introduces a correlation between scattering angle and radial displacement and performs a more precise calculation of the geometrical *safety* - the safe distance to the nearest boundary - before sampling the displacement. The default step restrictions guarantee at least two steps in the start volume and four steps in other volumes the track crosses. These modifications further minimize the relationship of simulated energy deposition with the user defined production cut in range.

This release included GFLASH, a parametrized shower production for the efficient simulation of calorimeter responses. A new *scoring mechanism* keeps tallies and records of integral dose and flux. The scoring classes are independent of sensitive detectors and are directly attached to logical volumes. A *scorer* keeps score without history so effectively throws away the hits. While there is this loss of information, the approach is standard in medical-dosimetry and calculations of radiation levels.

A new overlap detection algorithm checks for geometry overlaps at construction time when a volume is placed. It looks for overlaps with a sister volume or whether it protrudes from its mother. Points on its surface are sampled and an exception is generated if the point is outside the mother or inside a sister volume. The algorithm works for placement and parametrized volumes. Seven new CSG solids were introduced: G4TwistedBox, G4TwistedTrd, G4TwistedTrap, G4TwistedTubs, G4Ellipsoid, G4EllipticalCone and G4Tetrahedron. Also, the calculation of the normal vector of a surface for CSG solids was scrutinized, especially near corners

and edges.

With the release of Geant4.8.1 in the summer of 2006 all particle classes became non-static definitions. With 8.1 it became possible to create *User Limits* per G4Region. Neutrino-nuclei reactions were added to the CHIPS hadronic physics model. It was shown that the “Pythonization of Geant4” is possible. Work continued on DIANE, a distributed environment for Geant4 parallel processing on the GRID.

The first beta release of components to handle navigation in multiple geometries (parallel worlds) occurred with the release of Geant4.8.2 in December. A new G4PathFinder determines the correct path taking into account the response from multiple navigators, each attached to user-defined parallel geometries. Solids are now able to compute their surface area. Release 8.2 includes an enhanced algorithm for finding an intersection point with volume boundaries during propagation in fields. Particle definitions were updated to match PDG-2006 as well as the PDG encoding for nuclei. The G4Run object is now kept until the beginning of the next run during Idle state, so are the events objects until deletion of the run. A new class, G4NeutronKiller, allows for easy disabling the simulation of unwanted neutrons. The *Physics Lists* were moved into the source tree, thus simplifying the directory and library structure with only two granular libraries remaining. The multiple scattering process was further tweaked by modifying the minimum step limit calculation, with a weaker limit for high energy particles, and a modified angular distribution. A new class, G4hMultipleScattering, was added with step limitation only near boundaries for hadrons and ions. The process also received the optional possibility to reduce steps before boundary crossing. Geant4.8.2 has a library of polarized processes: e^+e^- annihilation, bremsstrahlung, Compton, ionization and e^+e^- pair production for simulation of circular polarized beams of e^+ and gamma. The existing Python module for steering Geant4 applications was enhanced and support for MacOSX was added. The visualization group demonstrated the ability to create movies with OpenGL. These are animated displays of events during time.

The CHIPS algorithm for electron and photon nuclear reactions was generalized for μ and τ leptons. Muon capture is particularly important for underground experiment background calculations estimating the production of neutrons and nuclear fragments. Process names G4Qx can be used instead of G4ElectronNuclearProcess, G4MuonNuclearProcess, G4PhotonNuclearProcess and G4MuonMinusCaptureAtRest. The nuclear μ capture at rest has a new approximation of the Hoop factor Q (decay delay), nuclear capture rate, total capture rate

and a new parametrization of the decay of a bound muon. A precise description of neutron spectra from μ nuclear capture at rest is a real challenge, but CHIPS (G4QCaptureAtRest) describes the experimental spectra better than G4MuonMinusCaptureAtRest.

The Geant4 collaboration is now paying more attention to profiling Geant4 applications and time performance. Hadronic shower shape studies continue with comparisons between data from calorimeter test-beams of LHC experiments (ATLAS HEC, ATLAS TileCal, CMS HCAL) and Geant4 simulation with LHEP and QGSP *Physics Lists*. Early conclusions are that cross sections as a function of energy are described well by LHEP and even better by QGSP. The e/π ratio is also described well by LHEP and even better by QGSP, but that hadronic shower shapes are shorter and narrower than data for QGSP, whereas LHEP looks somewhat better. QGSP and LHEP are similar at low and intermediate beam energies, with good agreement found with data for CMS but not for ATLAS. By adding cascade models (Bertini, Binary) the hadronic shower gets longer and wider. Adding precise low-energy neutron treatment (HP) does not affect the bulk of the hadronic showers but contributes to a larger tail. The relative contribution to the visible energy per particle type is $e \gg p > \pi > n$ and the electron dominance grows as the beam π^- energy increases. For pions and kaons below 10 GeV QGSP_BERT, which uses the Bertini model, is the current best one to use. It is the best *Physics List* we can offer at the moment for applications that rely on a good description of hadronic shower shapes. A report is in progress.

The Geant4 Collaboration Workshop and Users Conference was held this year in Lisbon in October. New data sets were distributed for high precision neutron processes (G4NDL 3.10), low-energy EM processes (G4EMLOW 4.1), and radioactive-decay processes (Radioactivedecay 3.1). The suggested CLHEP versions to use with G4.8.2 are 2.0.3.1 (or 1.9.3.1). Supported OS are: SLC3 with gcc 3.2.3 (being deprecated), SLC4 with gcc 3.4.6 (IA32 & AMD64) and gcc 4.1.1, MacOS 10.4 with gcc 4.0.1, SunOS 5.8 with CC 5.5 and Win/XP with VC++ 7.1/8.0.

The Geant4 Collaboration Oversight Board has decided to convene periodic external reviews to make an assessment of the collaboration activities and to provide feedback to the Collaboration Board with the aim of strengthening the collaboration and guide the choice of its future objectives. The mandate of the second such committee in 2007 is to investigate the physics precision, computational speed and general usability of the Geant4 software.

P. Gumplinger, TRIUMF
F.W. Jones, TRIUMF

The DRAGON Facility (D.A. Hutcheon, TRIUMF)

DRAGON is a facility for the study of radiative capture reactions by inverse kinematics, in which the beam is the heavy reactant and the target is the lighter one. The focus of the study is to measure reaction strengths of relevance in nuclear astrophysics.

Data collection for the stable-beam reaction $^{40}\text{Ca}(\alpha, \gamma)^{44}\text{Ti}$ was completed and the experiment is described in detail elsewhere. Other measurements using beam included: a measurement of recoil ion acceptance at a resonance of the $^{12}\text{C}(\alpha, \gamma)^{16}\text{O}$ reaction, allowing publication of results for that reaction; measurement of charge state distributions of ^{16}O ions following α capture by ^{12}C beam, leading to a publication; study of beam steering to check alignment of magnets in the separator. In addition, extensive measurements of separator acceptance were carried out using a source of α particles.

Separator acceptance

The DRAGON separator was designed to provide transmission of heavy recoil products up to a nominal reaction angle of 20 mrad. Detailed simulation which included beam emittance and scattering predicted $\approx 95\%$ transmission of recoils for a uniform distribution up to 20 mrad. However, this did not match what was found for ^{16}O recoils from the $^{12}\text{C}(\alpha, \gamma)^{16}\text{O}$ reaction at a beam energy where the maximum possible reaction angle was 18–19 mrad. The angular distribution inferred from the energies of transmitted recoil ions showed losses at the largest angles which were substantially larger than predicted by simulation of the system.

An experimental measure of separator transmission was obtained for one of the resonances of the $^{12}\text{C}(\alpha, \gamma)^{16}\text{O}$ reaction, at c.m. resonance energy 3.19 MeV. This 4^+ resonance is sufficiently strong that the cascade decay γ -rays could be identified clearly by the BGO detectors alone. The fraction of such events for which a recoil ion was detected in coincidence, 82%, is a measure of separator transmission for the resonance. GEANT simulation of the resonance found 13% higher transmission, indicating that some property of the separator was not adequately modelled.

Extensive studies of acceptance were made using a ^{148}Gd alpha source at the target location. A double-sided silicon strip detector (DSSSD) detected particles reaching one of three focus locations along the separator (so-called charge, mass or final focus). An aperture restricted the particles which entered the separator to cone half-angles of < 20 mrad. Subsets of these particles were defined by further aperture restrictions: angles

<6.1 mrad; “left” angles >7.1 mrad restricted to vertical angles -5.7 to $+5.7$ mrad; “right”, “up” and “down” angles obtained by rotating the “left” aperture. With a rate of 23 s^{-1} alphas through the largest aperture and $1/10$ of that rate through the smaller apertures, data collection with good statistics was time-consuming.

The DSSSD hit patterns indicated that the most symmetric distributions at the three focus points were obtained with the alpha source 2 mm higher than the usual position of beam through the gas target. However, the higher source position did not improve transmission through to the end of the separator of the full 20 mrad cone ($68.4\pm 0.4\%$ vs. $70.2\pm 0.5\%$ at the usual beam height). In contrast, GEANT simulation predicted 95% transmission. Another feature of the alpha work was stronger-than-expected coupling between vertical and horizontal motion. Continuing studies will focus on identifying more precisely where the unexpected losses are occurring.

Magnet alignment

DRAGON target and separator elements were installed in 2000–2001 to the height defined by upstream beam line, the reference height being copied also to a nearby pillar at the south side of the experimental hall. Recent checks of the target height showed it to be 1.5 mm high with respect to the reference mark on the pillar. This was surprising in light of the fact that the alpha source studies suggested the regular target position was too low.

Further measurements were made of the heights of diagnostic items and of the dipole magnet poles relative to the reference height. They revealed that the target, first separator dipole (MD1) and the slits after MD1 all were higher than the reference mark by 1–2 mm but the second dipole (MD2), which is near the south pillar, was 1.7 mm below the reference height. This strongly suggested that the floor in the middle of the experimental hall had risen with respect to floor near the south side of the hall. A further sign of floor movement was provided when it was found that the poles of MD1 and MD2 were no longer level, and that slope changes up to 1 mm across a 1 m horizontal distance had taken place.

It is unclear whether such deviations significantly affect separator acceptance; standard tuning procedure uses steering magnets to re-centre the pilot beam on diagnostic devices in each leg of the separator, which should dampen out magnet steering due to misalignments. We plan to install fixtures on quadrupoles to allow better monitoring of possible future movements of the floor, and to tie the survey data to measurements of the magnetic axes of the quads.

Charge state distributions

Sometimes it is not feasible to measure several charge states of the recoil ions from a capture reaction, and the charge state distribution (CSD) must be calculated from other data. There are three components to such a calculation: evolution of the CSD of beam ions in the gas target before capture occurs; changes in charge states at the time of capture; evolution of the CSD of recoil product ions as they pass through the remainder of the gas target. Usually it is the last of the three stages which determines the CSD of the emerging product ions, in which case the CSD may be measured using a beam of the same atomic number as the recoil product. However, for a broad resonance or higher beam energies the middle stage may have a strong bearing on the final CSD.

We have studied this question using the strong reaction at c.m. energy 3.19 MeV in $^{12}\text{C}(\alpha, \gamma)^{16}\text{O}$, measuring the relative numbers of ^{16}O ions in the 6^+ and 5^+ charge states as a function of gas target pressure. Separate measurements of the evolution of CSD of the C beam in He gas and of an O beam in He gas provided the data to model the first and last of the three above-mentioned stages. Various assumptions about the middle stage—charge change during capture—could then be compared with the data from the capture reaction. Variation of target gas pressure provided variation in populations of C ions at the time of capture, from the incoming beam which was 100% in the 3^+ state towards equilibrium of 50% 5^+ and about 25% in each of 4^+ and 6^+ states.

The model which best accounted for our data assumed that none of the electrons of the He target atom was captured at the time the He nucleus was captured by the incident C ion (see Fig. 1). Indeed, it appeared necessary to assume that Li-like C ions (3^+) might form He-like O ions about 10% of the time, in order to account for data from the Bochum group on the 6^+ fraction as a function of target pressure. This stands in contrast to a common assumption that the charge state of the recoil ion is the same as the charge state of the beam ion; that the electrons of the target atom are picked up along with its nucleus. The results have been published in Nuclear Instruments and Methods B.

Electrostatic dipoles

The high voltage stacks for the electrostatic dipoles ED1 and ED2 are housed in cylinders which extend inward from the outside vacuum tank, towards the electrodes. The cylinders must withstand voltage differences up to 200 kV and contain 2 atm (absolute) of SF_6 insulating gas. As reported in 2005, the nylon cylinders installed in ED1 developed breakdown prob-

lems due to buildup of conductive material on their outside surfaces (the high-vacuum side). At that time they were replaced by cylinders of another organic material, polyethylene.

This year we found a manufacturer who was able to produce ceramic (alumina) cylinders in the shape we required. The polyethylene cylinders of ED1 were replaced by ceramic versions for both anode and cathode high voltage supplies. ED1 was conditioned up to 200 kV without the breakdown problems that had been experienced with the nylon cylinders. Dipole ED2, for which we had been able to obtain ceramic tubes during initial installation, has shown no breakdown problems up to its maximum design voltage of 160 kV.

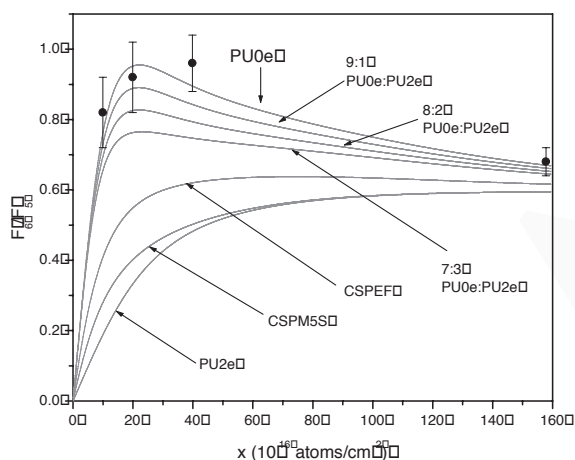

Fig. 1. Ratio of $6^+ : 5^+$ charge states in the recoils of $^{12}\text{C}(\alpha, \gamma)^{16}\text{O}$ as a function of target thickness. The solid lines are different models of electron pick-up or loss during the nuclear capture. PU0E has 0 electrons of the He atom picked up by the O recoil, PU2E has 2 electrons picked up.

8 π Spectrometer (G.C. Ball, TRIUMF)

The 10 element BaF_2 detector array DANTE (Dipentagonal Array for Nuclear Timing Experiments) was installed in June 2006 and the beam required for the initial commissioning experiment, namely ^{112}Ag was also developed by the TRILIS group. The first run with DANTE is presently scheduled for July 2007 (see E984, TRIUMF 2004 Annual Report for more details on this project).

In October, 2006 the air-condition unit for the 8 π electronics shack was upgraded to provide the cooling required because of the increase in the ambient temperature in the ISAC-I experimental hall and because of the additional heat load resulting from the electronics required to operate the four detector systems (20 HPGe array, SCEPTAR, PACES and DANTE) in parallel.

Development was also initiated to design and fabricate a new automated LN_2 filling system for the HPGe detector array to replace the one which has been in operation since 1985. The new system is based on the one developed for the TIGRESS array. The new system should be operational in early 2007.

In March, 2006 a high-powered Ta target was used to produce ^{38m}K to search for the non-analogue 0^+ decay of this superallowed β -emitter. The details of this experiment are presented separately (see E823 TRIUMF 2006 Annual report).

In May, 2006 the β -decay of the neutron rich $^{51-53}\text{K}$ isotopes produced using a high-powered Ta target was studied as part of a program to systematically measure the properties of excited states in the neutron-rich Ca isotopes towards the doubly-magic ^{54}Ca (see E1064 TRIUMF 2006 Annual Report for more details).

In July 2006 the 8 π spectrometer and PACES (Pentagonal Array for Conversion Electron Spectroscopy) were used to continue the investigation of coexisting collective phases in $N=90$ isotones. This run was focused on the β -decay of ^{160}Lu but additional data were also obtained for the decay of ^{156}Ho . The results of this experiment led by D. Kulp from Georgia Tech. are reported separately (see E973, TRIUMF 2006 Annual Report).

The use of the 8 π gamma-ray spectrometer for high-precision β -decay lifetime measurements has been reported previously (see E909, TRIUMF 2002-4 Annual Reports). In November 2006, the third attempt to obtain a ^{34}Ar beam (this time during the commissioning of the new TRIUMF FEBIAD ion source) for a high-precision lifetime measurement of this superallowed β -emitter failed to produce the beam intensity required. The FEBIAD is presently undergoing modifications that will hopefully resolve this problem. A preliminary analysis of the data obtained in November is reported separately (see E909 TRIUMF 2006 Annual Report).

Finally, an offline source experiment was carried out for approximately 6 weeks during the summer, 2006 to study the β -decay of the long-lived ($t_{1/2} = 160$ days) high-K isomer ^{177m}Lu . The motivation for this experiment is essentially the same as for $^{178m2}\text{Hf}$ decay, where the 8 π array was able to identify weak transitions at a level of about 1 part in 10^5 decays. From these data the existence of strongly K-forbidden transitions of M4 and E5 character from the 16^+ isomer were established and a linkage between the two 8^- bands of related structure was found that had been hinted at by preliminary results from JINR (see M.B. Smith *et al.*, Phys. Rev. C58 (2003) R31302 for details).

The high-K isomer ^{177m}Lu decays by both IT and β - channels. The direct β -decay from ^{177m}Lu populates

^{177m}Hf (1.08 s), so an improved measurement of the decay paths also provides some chance of new information about the daughter nucleus. No β -decays are currently known from ^{177m}Lu that bypass that target level. The presence of such transitions could be indicative of a significantly reduced K hindrance. For IT decay of the lutetium isomer, the possibility exists of a weak M4 transition at 334 keV, similar to the high-multipolarity transitions found at TRIUMF for $^{178m2}\text{Hf}$ decay. Making an assumption of a similar reduced K hindrance, this 334 keV might occur with an intensity near 10^{-4} compared with the known 115 keV decay transition. This experiment was led by J.J. Carroll from Youngstown State University.

There are currently 19 approved ISAC experiments that will use the 8π spectrometer (E823, E909, E921, E929, E954, E955, E957, E961, E973, E984, E985, E988, E1007, E1008, E1028, E1054, E1059, E1064, E1068). During the past year a total of 48 collaborators from 14 institutions actively participated in the development and/or use of the 8π spectrometer.

EMMA, the Electromagnetic Mass Analyser (*B. Davids, TRIUMF*)

EMMA is a recently funded recoil mass spectrometer for ISAC-II. Starting in 2007, ISAC-II will provide intense, low-emittance beams of unstable nuclei with masses up to 150 u and eventual maximum energies of at least 6.5 A MeV. Now that the first stage of the accelerator is complete, it is essential that ISAC-II be instrumented with experimental equipment to exploit what will be the world's most intense radioactive beams at Coulomb barrier energies. The advanced γ -ray spectrometer TIGRESS is fully funded and will be the first apparatus regularly available for experiments. TIGRESS will be used in many different types of experiments with radioactive beams, especially those involving fusion-evaporation and transfer reactions. However, the detection of γ -rays alone is seldom sufficient for a successful measurement. Background radiation from more likely reactions usually obscures the signal of interest, and additional measurements are required to isolate the γ -rays emitted by the recoil nucleus being studied. The same problem occurs when using charged particle detectors to investigate transfer reactions. In

both cases, direct detection and unique identification of the recoil nucleus results in tremendous background reduction, enabling experiments that otherwise would be impossible. Therefore, an efficient and selective recoil mass spectrometer, possessing large acceptances in angle, mass, and energy without sacrificing the necessary beam suppression and mass resolution, is urgently needed for the ISAC-II science program.

An ion optical design study for such a recoil spectrometer has been completed. The design for EMMA is based on a symmetric configuration of electric and magnetic dipoles, a proven design that provides for energy dispersion cancellation. However, our new design represents a significant improvement over existing instruments of this type. In particular, EMMA will have the largest energy and angular acceptances of any recoil mass spectrometer, while simultaneously providing high mass resolving power due to the design of its magnetic quadrupole lenses and the curvature of its magnetic dipole field boundaries. This combination of large acceptance and high resolution will make EMMA the most advanced instrument of its kind. It will be an indispensable part of the ISAC-II experimental facility. Figure 1 depicts a conceptual layout of EMMA.

After an unsuccessful application for funding in the 2005 subatomic physics grant competition, EMMA was the subject of a \$2.085 M NSERC RTI grant proposal in the 2006 competition. The initial 2006 disbursement of \$85 k was followed by a \$500 k payment. Three more annual \$500 k installments are expected from NSERC, the last of which will arrive in 2009. TRIUMF management has deemed the project so essential to the future of the laboratory that it has pledged \$1 M toward its construction. Moreover, TRIUMF has promised to make funds available quickly in order to allow the large electromagnetic elements, which are the most expensive and longest lead-time components, to be ordered promptly, hastening the construction of the spectrometer. The detailed specifications have been written and reviewed internally at the laboratory. Hence we anticipate that tender requests will be issued in the winter of 2007, and an order placed with the successful bidder in spring 2007. This should allow for delivery of the large electromagnetic components in 2008 and commissioning in 2009, well ahead of the NSERC timeline.

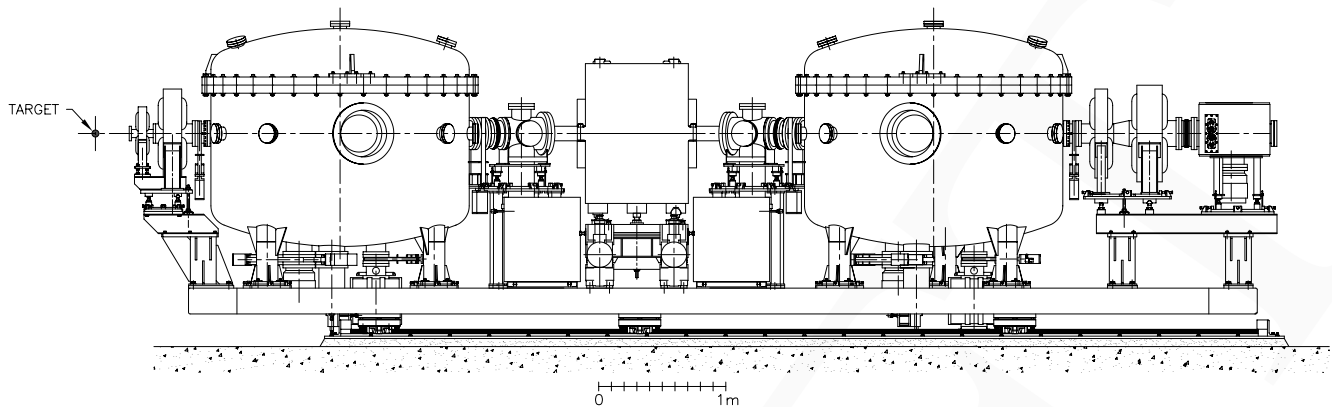

Fig. 1. Conceptual layout of EMMA, the Electromagnetic mass analyser.

TIGRESS

(G. Hackman, TRIUMF)

The year 2006 marked the beginning of the TIGRESS (TRIUMF-ISAC Gamma-Ray Escape Suppressed Spectrometer) scientific program. The results of an in-beam experiment with ^{21}Ne , ^{21}Na and ^{20}Na beams built upon those accomplishments from this and previous years. The scientific justification, goals, and outcome of this beam-time is discussed in the report on E1058. Progress on all fronts continued; the only setback was a complete redesign of the ISAC-II beam lines, which resulted in a major redesign of the detector support structure.

TIGRESS detectors

At the end of 2006, six HPGe clovers were onsite. Of these, three (No. 1, 3, 4) had been fully tested, characterized and accepted, and were ready for use in experiments. Two more (No. 2 and 5) exhibited a ringing with a 70 ns risetime. In response to this, No. 2 was returned to the vendor for a retrofit. This retrofit eliminated the ringing while increasing the preamplifier risetime from 40 to 50 ns. Final testing of No. 2 and No. 5 continue. A field repair is planned for No. 3 and No. 4 in early 2007. Initial testing of No. 6 showed that this unit simultaneously met our specifications for energy resolution, preamplifier risetime response, insensitivity to ambient acoustical noise, and electronic inter-contact crosstalk not associated with physical, position-dependent induced signals.

At the end of 2006, five complete sets of suppressor shields were onsite. One side-shield unit was returned for excessive variation in phototube responses, but otherwise, all those delivered have been accepted. No setbacks are expected.

In May 2006, detector engineers from the HPGe clover vendor visited the site and provided training on installation of the side suppressor shields on the HPGe cryostat.

Auxiliary detectors: BAMBINO

A collaborative effort between scientists at University of Rochester and Lawrence Livermore National Laboratory, has led to the delivery of the first auxiliary detector hardware for TIGRESS. BAMBINO comprises a CD-sized silicon detector with 16 angular-segment contacts on one side and 24 ring contacts on the other. It includes a vacuum vessel with thin Al housing, to minimize gamma-ray absorption; a five-position target ladder; beam line ports for coupling to a standard ISAC beam line; preamplifiers, power supplies, and bias supplies. BAMBINO was shipped and tested at TRIUMF prior to use in-beam. This device was used for the first TIGRESS radioactive beam experiment.

Université Laval provided a fast plastic scintillator to count heavy ions transmitted through the target. This detector was not incorporated into the TIG-10 system, and was used primarily as a beam diagnostic element.

TIG-10 Rev.2

A second version of the TIG-10 cards (Rev.2) was developed and delivered by Université de Montréal. The front-end analogue network to suppress ground loops performed as expected, and is implemented in the new hardware. Revision 2 now also allows software selection of gain and offset. This improves the flexibility of the TIG modules as the cards can now accommodate positive, negative, or bipolar signals without hardware modification. Two LEMO connectors now allow programmable NIM input and output. Power distribution was also redesigned. On the firmware side, the triggering structure was redesigned to be based on logic blocks, each of which is conceptually similar to an “old-fashioned” network of NIM modules comprising majority logic and gate and delay modules. This allows more intuitive and flexible trigger decisions at the first, TIG-10 level. For the in-beam experiment,

the NIM outputs were programmed to reflect TIG-10 first-level trigger conditions, which were then sent to scalers for diagnosing the performance of the detectors. The rates in angular segments of the BAMBINO silicon detectors were monitored for evidence of changes in position of the beam.

Collector and master cards were also implemented during this year. The same “old-fashioned” trigger logic blocks are implemented for mid-level collector and high-level master trigger decisions. Data acquired by the TIG-10s is transmitted to the collector cards and read out by the VME backplane. The collector and master cards are physically identical hardware; the only difference is in the FPGA programming.

The in-beam experiment used the full three-level triggering system. A variety of trigger modes were programmed into the FPGAs from the MIDAS back-end computer. Various singles modes for calibration, down-scaled BAMBINO triggers, and coincidences between the TIGRESS HPGe and BAMBINO silicon were all implemented and used during the experimental setup, in beam, and during offline calibration. Correct operation of the readout system represented an important milestone, as the three-level depth of the system represents the highest level of hierarchical complexity that is anticipated. Additional TIGRESS clover units and more complicated auxiliary detectors will simply represent a scalable, horizontal growth in the readout system.

Signal simulation and decomposition

One challenge that remains for all position-sensitive HPGe detectors is to generate reliable, accurate simulations of the position-dependent waveforms. It is generally accepted that poor understanding of the mobility of holes at high electric fields in crystal germanium is at the root of these discrepancies.

This year the collaboration focused on including additional instrumentation effects, namely preamplifier response and transmission-line distortion. Preamplifier response has been a difficult and open question. Although the square-wave response can be directly measured for the core contacts, there is no similar probe for the outer-segment contacts. As such the preamplifier risetime to date has been treated as a “free parameter” in the simulations. Early in 2006, a schematic for the PSC823 preamplifiers was obtained and implemented in a PSPICE simulation. Interestingly, the PSC823 response is actually quite well represented by a response similar to a simple RC circuit. This simplified response had been used in previous signal simulations and has a simple analytical form. The transmission line distortion arising from finite-length coaxial cables can also be, in principle, represented analytically. These effects are also now included in the simulations. With

these improvements the simulations still fail on hole-dominated signals from interactions near the detector cores, and inclusion of these instrumental effects did not remove the systematically low differential induced-signal size. This rules out instrumental effects for the former, and tends to confirm the hypothesis that the hole mobility inputs to the simulations are incorrect. The latter effect is still unexplained. Details of these results may be found in the co-op work term reports of Elena Bassiachvili.

The collaboration was invited to attend a workshop where the first attempts were made to apply a Singular Value Decomposition (SVD) algorithm for waveform analysis of multiple-interaction events in GRETINA-style detectors. This experience was brought back to TRIUMF and first implementation to TIGRESS data is anticipated for 2007.

Mechanical structure

The first prototype detector stand revealed a number of potential issues with the overall operation of the full array. A second prototype detector stand was fabricated to address many of these issues, including the stability of HPGe detectors on the frame and alignment of the retractable front suppression shields. Both single-detector stands were modified.

Fabrication of the superstructure commenced in 2006. The corona and lampshade rings, as well as the half-rings and bottom truck-plate, were being fabricated at Canadian CNC in Richmond, B.C. Leg components were fabricated locally at TRIUMF. Final assembly of the superstructure and delivery to TRIUMF is expected in spring 2007.

A new beam line design for the ISAC-II experimental hall was adopted in early 2006. This required a new design for the mechanical structure with a rigid I-beam subframe that could be moved to arbitrary locations. This design was completed in 2006 and fabrication is well underway.

Meetings and roadmap

In February 2006, Colorado School of Mines (CSM) hosted a meeting between the TIGRESS collaboration and a group led by University of York and CSM determined to build and install a set of high granularity silicon-strip and CD-type detectors for use as an auxiliary detector with TIGRESS at ISAC-II. These detectors would be used primarily for light charged-particle reactions in inverse kinematics, e.g., $^{24}\text{Na}(p, p'\gamma)$. This meeting fixed design parameters for the silicon device.

A second Scientific Roadmap meeting was hosted by Saint Mary's University, Halifax.

Outlook

In 2007, TIGRESS will move to its “permanent” home in the ISAC-II experimental hall. The SEBT3A beam line will be its first home, where it

will be installed with a beam dump. An enclosed, air-conditioned electronics hut will be installed to serve both the SEBT3A (standalone) and SEBT3B (EMMA) positions. The first experiments at ISAC-II will use BAMBINO.